

## RESIN DRYING HOPPERS AND STANDS

# CONSOLIDATED RESIN DRYING HOPPER SYSTEMS

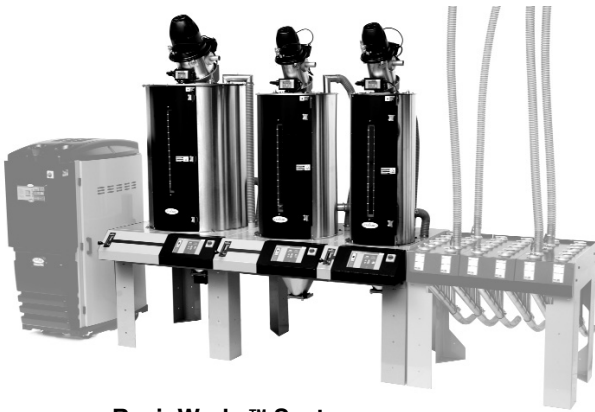

**ResinWorks™ System**  
W400 Dryer Shown with  
RWH 33-21, RWH 24-12 and  
RWH 18-6 Hoppers.

Conair ResinWorks™ systems offer a new level of manufacturing efficiency. By consolidating resin handling and pre-conditioning into a central area, material changes can take place quickly, cleanly, and safely away from the processing machine. Simplified resin dehumidification is the heart of the ResinWorks system, where multiple hoppers are supplied on a common, pre-plumbed, pre-wired sled, and connected to a dehumidifying dryer to provide superior drying and maximum productivity. Individual sleds can be connected to form an efficient, centralized resin drying area supplying large numbers of processing machines with a wide array of dried resins.

## RUGGED HOPPER STANDS INCORPORATE HEAT AND AIR CONTROL

ResinWorks central drying systems are designed to solve real-world productivity challenges. Energy and time saving features create an efficient central drying system. Starting with simplified shipping and installation, ResinWorks continually improves your bottom line.

Integral supply and return manifolds carry dehumidified air from your central dryer. Individual hoppers are easily isolated for clean out by dual air valves opened and closed with a single hand lever. This 3-position lever located beside the temperature controller provides fool-proof 'On/Off' operation for both heat and airflow. Three-phase disconnects at each sled conveniently distribute power to all hoppers.

Stainless steel drying hoppers provide exceptional air distribution and material mass flow. Removable air spreader cone and extra-large access door minimize clean out time. Use the hopper's extra-long sight glass with optional sensor bracket and sensor kits to easily adjust and indicate material level.

### ■ Quick clean hoppers

Located within easy operator reach, each hopper includes the industry's largest clean-out doors, a removable cone, and smooth all-stainless steel construction.

### ■ Superior mass flow

Design assures that all material is evenly exposed to dry air and heat. Funnel flow and material hang-up points are eliminated for superior drying.

### ■ 100% insulated

From the base of the cone, to the oversized door, to the full body wrap, each hopper is designed to preserve heat and save energy.

### ■ Long life tube heaters

Highly accurate, compact 'tube' heaters are located at the inlet of each hopper for superior temperature control and minimal energy loss.

### ■ Super safe hopper control

Air is turned on and off with the exclusive ResinWorks control lever. Safe. Simple. Foolproof.

### ■ Automatic airflow balancing **NEW**

Earlier designs meant having to independently adjust each hopper for proper airflow now, with this new design, there will never be any adjustment needed.

**RESIN DRYING HOPPERS AND STANDS**

MODEL	RWH14-3	RWH18-6	RWH24-12	RWH24-18	RWH33-21	RWH33-28	RWH39-35†	RWH39-42†	RWH44-58‡	
FIGURE NUMBER	Fig. 1	Fig. 1	Fig. 1	Fig. 1	Fig. 1	Fig. 1	Fig. 2	Fig. 2	Fig. 2	
<b>Performance characteristics</b>										
Volume ft³ {liter}	3.0 {85.0}	6.0 {170.0}	12.0 {340.0}	18.0 {509.0}	21.0 {595.0}	28.0 {793.0}	35.0 {991.0}	42.0 {1189.0}	58.0 {1643.0}	
Capacity @ 35 lb/ft³ lb {kg}	105.0 {48.0}	210.0 {95.0}	420.0 {191.0}	630.0 {286.0}	735.0 {333.0}	980.0 {445.0}	1225.0 {556.0}	1470.0 {667.0}	2030.0 {921.0}	
Capacity @ 52 lb/ft³ lb {kg}	156.0 {71.0}	312.0 {142.0}	624.0 {283.0}	936.0 {425.0}	1092.0 {495.0}	1456.0 {660.0}	1820.0 {826.0}	2184.0 {991.0}	3016.0 {1368.0}	
Air inlet/outlet OD {mm}	2.5 {64.0}	2.5 {64.0}	2.5 {64.0}	2.5 {64.0}	5.0 {127.0}	5.0 {127.0}	5.0 {127.0}	5.0 {127.0}	5.0 {127.0}	
Inside diameter OD {mm}	14.0 {356.0}	18.0 {457.0}	24.0 {610.0}	24.0 {610.0}	33.0 {838.0}	33.0 {838.0}	39.0 {991.0}	39.0 {991.0}	44.0 {991.0}	
Material inlet	IT06	IT07	IT07	IT07	IT07	IT07	IT07	IT07	IT07	
Material outlet ID {mm}	2.0 {51.0}	2.0 {51.0}	2.0 {51.0}	2.0 {51.0}	3.0 {76.0}	3.0 {76.0}	3.0 {76.0}	3.0 {76.0}	3.0 {76.0}	
Material discharge (bottom)	IB02	IB02	IB02	IB02	IB02	IB02	IB03	IB03	IB03	
<b>Voltages full load amps§</b>										
Heater kW	4		10				30			
208 V/3 phase/60Hz	11.4	11.4	21.2*	21.2*	21.2*	21.2*	n/a	n/a	n/a	
230 V/3 phase/60Hz	10.3	10.3	25.3	25.3	25.3	25.3	n/a	n/a	n/a	
400 V/3 phase/50Hz	5.9	5.9	14.5	14.5	14.5	14.5	43.7	43.7	43.7	
460 V/3 phase/60Hz	5.1	5.1	12.7	12.7	12.7	12.7	38.0	38.0	38.0	
575 V/3 phase/60Hz	4.1	4.1	10.2	10.2	10.2	10.2	30.4	30.4	30.4	
<b>Dimensions inches {cm}</b>										
<b>Standard sled</b>										
A - Overall height †	78.7 {200.0}	86.5 {219.7}	92.6 {235.2}	116.3 {295.4}	107.5 {273.1}	118.5 {300.9}	121.5 {308.0}	132.5 {337.0}	138.5 {352.0}	
B - Height below mounting flange	29.3 {74.0}	25.6 {65.0}	20.6 {52.3}	20.6 {52.3}	24.0 {61.0}	24.0 {61.0}	19.5 {50.0}	19.5 {50.0}	14.5 {37.0}	
C - Panel height	41.3 {104.8}	41.3 {104.8}	41.3 {104.8}	41.3 {104.8}	41.3 {104.8}	41.3 {104.8}	41.8 {106.0}	41.8 {106.0}	41.8 {106.0}	
D - Sled width	25.0 {63.5}	25.0 {63.5}	36.0 {91.4}	36.0 {91.4}	45.0 {114.3}	45.0 {114.3}	69.0 {175.3}	69.0 {175.3}	74.0 {187.9}	
E - Depth	51.3 {130.3}	51.3 {130.3}	51.3 {130.3}	51.3 {130.3}	51.3 {130.3}	51.3 {130.3}	59.0 {150.0}	59.0 {150.0}	64.0 {162.0}	

**SPECIFICATION NOTES:**

\* Uses 230V heater derated to 7.5 kW.

† For multi-hopper sled, be sure to use the largest hopper as the reference for the overall height dimension.

‡ Conair 39 and 44 inch hoppers are mounted on individual sleds.

§ FLA ratings are per hopper. FLA ratings for a ResinWorks sled is the sum of the sled's individual hopper FLA ratings.

Specifications can change without notice. Contact a Conair representative for the most current information.

**OPTIONS**

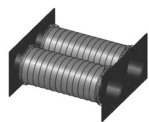

■ **Multiple Sled Connection Kit**  
This option allows the connection between multiple sleds for the integral supply, return and conveying manifolds. For each junction between sleds a kit is required.



■ **Precision Slide Gate**  
Use the precision Slide Gate to prevent material leakage when no purge valve or distribution box is specified on the hopper.



■ **Adjustable Purge Valve**  
New design! This valve controls material flow from material source to destination. This easy to clean and install valve has a discharge that rotates 360 degrees to allow complete purge of material lines.

■ **Communications**  
Options include:  
Modbus and DeviceNet.



■ **Hopper Discharge Drain Port**  
Facilitates hopper draining and clean out.

■ **Temperature Setback RTD**  
Automatically reduces the drying temperature to a lower standby mode when the machine throughput is reduced or stopped.

**RESIN DRYING HOPPERS AND STANDS**

Depending upon hopper requirements, ResinWorks drying systems may be configured with single-hopper sleds, multiple-hopper sleds or a combination of both.

**Multi-Hopper Sled**

Figure 1

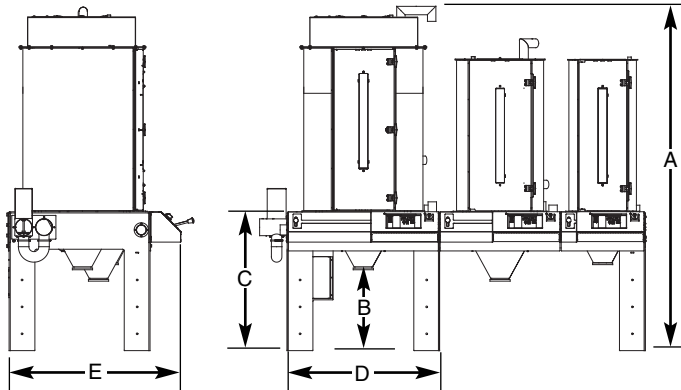

**Single-Hopper Sled**

Figure 2

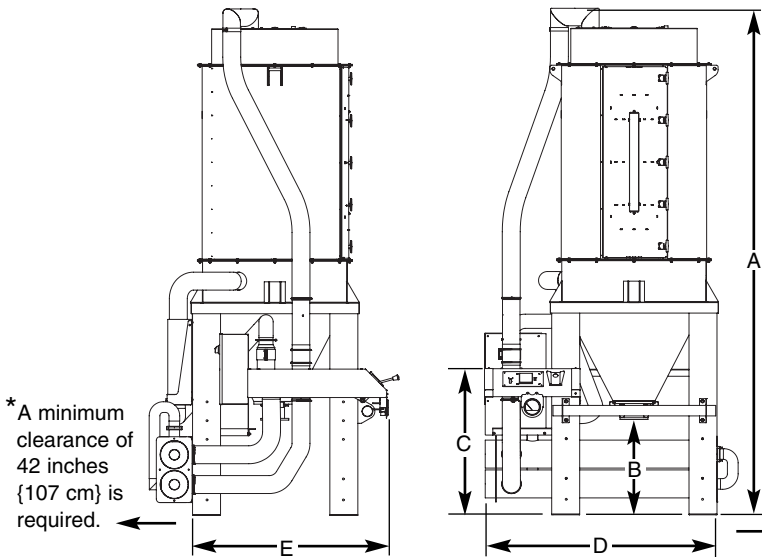

\* A minimum clearance of 42 inches {107 cm} is required.

**Available Hopper Combinations**

Figure 3

RWH Hopper Models possible sled combinations				Sled Total Length	
				in. {mm}	ft. {cm}
33				45 {1143}	3.8 {116}
33	33			90 {2286}	7.5 {229}
33	33	24		126 {3200}	10.5 {320}
33	33	14/18		115 {2921}	9.6 {293}
33	24			70 {1778}	5.8 {177}
33	24	24		95 {2413}	7.9 {241}
33	24	14/18	14/18	131 {3327}	10.9 {332}
33	14/18	14/18	14/18	120 {3048}	10.0 {305}
24				36 {914}	3.0 {91}
24	24			72 {1829}	6.0 {183}
24	24	24		108 {2743}	9.0 {274}
24	24	14/18		97 {2464}	8.1 {247}
24	24	14/18	14/18	122 {3099}	10.2 {311}
24	14/18	14/18	14/18	111 {2814}	9.3 {283}
14/18				25 {635}	2.1 {64}
14/18	14/18			50 {1270}	4.2 {128}
14/18	14/18	14/18		75 {1905}	6.3 {192}
14/18	14/18	14/18	14/18	100 {2540}	8.3 {253}

NOTE: Conair 39 and 44 inch hoppers are mounted on their own individual sleds. (see Fig. 2)

Use Figure 3 to identify the available hopper combinations that would be right for your operation, and determine the overall width of each multi-hopper sled. More specific dimensions for hoppers can be found on the previous page, in the specifications table.

\* A minimum clearance of 14 inches {35.6 cm} is required.

Hoppers that are 33 inches in diameter and smaller may be joined together onto a single sled and shipped as a unit, installed as a unit and connected into your drying system as a single unit (see Figure 1). This consolidation greatly saves time and expense and once connected to the proper central drying unit, provides an optimum dehumidification system for all of your resins. Hoppers 39 inches and over in diameter are provided on their own individual floor stands (sleds) and each is equipped with air connections, heater, control, etc. (see Figure 2).

# Discover



Systems that are conceived, configured and designed to make you more competitive, efficient, productive and profitable.

- **Provides full flexibility** – any material to any machine at any time.
- **Ten minute material changes** – pre-dried, pre-blended material always ready.
- **Clean, neat processing** – removes drying and blending equipment from the machine area.
- **Convey small batches** from dryer or blender to machine.
- **Conveying lines purged** after every cycle.
- **Minimizes labor**, energy, material and inventory costs.



ResinWorks **drying hopper sleds** can accommodate **up to four drying hoppers**, each sized specifically for either multi-machine, long run or single machine, short run operations. The sled is shipped with drying hoppers, heaters, controls, dry air manifolds and purge valves pre-assembled for easy installation.

## The difference is in the details.

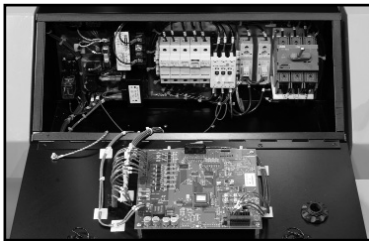

We've eliminated the need for additional clearance behind the sled by relocating all electrical access points to the front of the sled. Now you can save valuable floor space and reduce troublesome equipment location problems.



The Conair ResinWorks mass flow, stainless steel, drying hopper is equipped with an oversized door for quick, easy clean out and thorough material changes. A full length sight glass with level indication lets you see your material level at a glance.

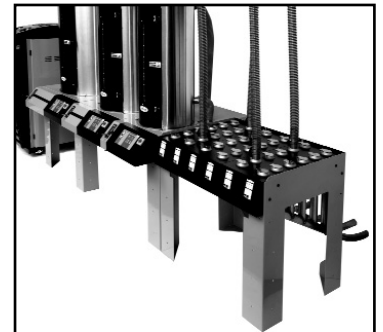

Integrated supply and return air manifolds replace the externally mounted bulky manifolds for a simplified installation of material conveying lines to each hopper.

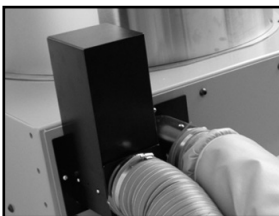

The new fully automatic airflow balancing valve eliminates the need for tedious individual airflow adjustments at each hopper.



Each hopper is now equipped with individual three-phase disconnects allowing you to independently shut off one hopper without disrupting production.