



victory



Series

- > ENGEL victory
- ENGEL e-motion
- ENGEL e-max
- ENGEL duo
- ENGEL speed
- ENGEL combimelt
- ENGEL insert
- ENGEL elast / LIM
- ENGEL PETsystems

Integrative technology

- ENGEL robot
- ENGEL control

Services

- ENGEL training
- ENGEL e-factory

Application technology

- ENGEL application technology

Industry sectors

- ENGEL automotive
- ENGEL teletronics
- ENGEL packaging
- ENGEL medical
- ENGEL technical moulding

Summary

- ENGEL portfolio

Language

- german
- > english
- french
- italian
- spanish
- chinese
- russian
- czech
- polish



ENGEL

be the first.

ENGEL

be the first.

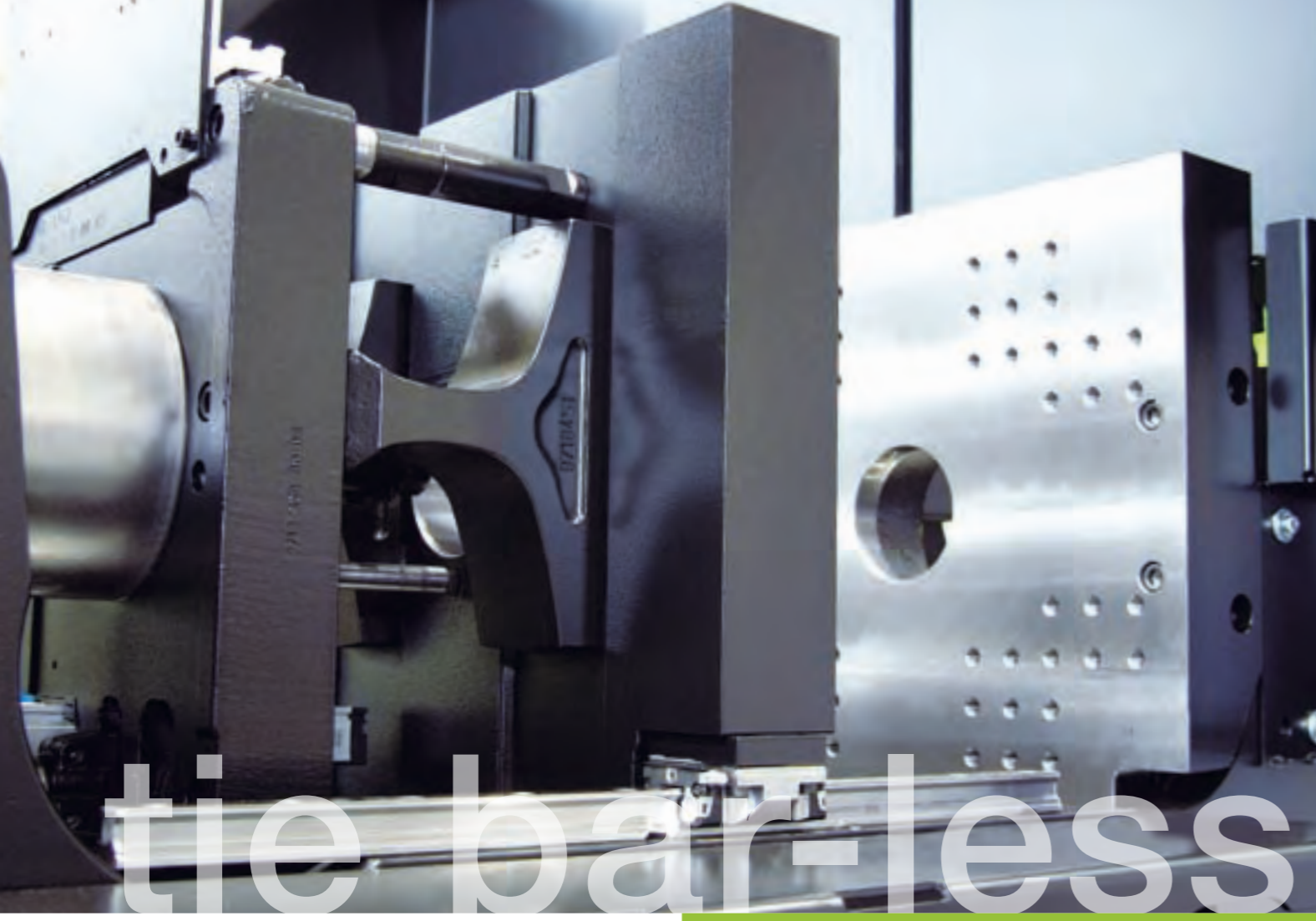

The universal machine system for all plastic injection moulding products

Machines that offer the benefit of the tie bar-less clamping unit:

- > Superior production efficiency thanks to ergonomic benefits of the tie bar-less clamping unit, such as minimum retooling times (even for bulky moulds), barrier-free access for robots, or unrestricted use of the platen surface
- > Platen parallelism for exacting precision requirements
- > Comprehensive modular machine system that offers the perfect conditions for both standard and custom applications including multiple component injection moulding
- > Excellently suited to clean room applications thanks to „simple“, easily accessible, and therefore easily cleaned, tie bar-less clamping unit
- > Comprehensive portfolio in the small to mid-range machine field with clamping forces between 280 and 6,000 kN
- > Easy to operate thanks to intuitive, logically, graphically visualised user interface on the ENGEL EC 200 or CC 200 type control units
- > Available for fast delivery worldwide due to globally standardized production in ENGEL's facilities in Europe, Canada and Korea

Tried and trusted system: More than 40,000 machines supplied, and successfully utilized by our customers, since 1989



individual

Tie bar-less machines for universal applications

Synthetics shape our world and give us the ability to live more individual lives. The demand for individuality continually requires new answers; synthetic moulded parts and injection moulding play an important role in providing them. The unique tie bar-less system, a standardised technology platform with more than 360 modules are what give the ENGEL victory machine range the potential to turn your creativity into tangible products.

The System – the Platform, the Modules

The system

The ENGEL victory injection moulding machine range is based on the tie bar-less clamping unit design that was first introduced to series production by ENGEL in 1989. The advantages are barrier-free access to the clamping unit, and more efficient use of the mounting surface.

This saves tooling time and simplifies automation. ENGEL victory machines are available with clamping forces of between 280 and 6,000 kN, and cover the whole range of applications in the small to mid-sized field.

The Platform

The machine system consists of a globally identical basic technology: the technical platform including a tie bar-less clamping unit and injection unit, along with a modular system of comprehensive, application-oriented equipment and extension packages.



Since they were launched more than 40,000 units have been produced in ENGEL's three production facilities in Austria, Canada and South Korea for delivery worldwide. The current series represents the fourth generation.

The Modules

ENGEL victory **focus** // The machine that focuses on the essentials.

- Tie bar-less clamping unit with standard platens
- Compact hydraulic injection unit
- Standard barrel and screw
- Pump controlled hydraulics for sequential movements
- EC 200 machine control unit

ENGEL victory **tech** // The economic machine for all standard applications.

- Clamping unit with extended platens
- Compact hydraulic injection unit
- Standard barrel and screw
- Variable displacement hydraulic pump for sequential movement, extendable for parallel movement and maximum plasticizing and injection performance
- Standard type plasticizing unit
- Comprehensive list of options
- EC 200 machine control unit

ENGEL victory **power** // Five performance levels geared to your requirements – for demanding precision parts.

- Clamping unit with extended platens
- Compact hydraulic injection unit
- Variable displacement hydraulic pump for parallel movement and maximum plasticizing and injection performance
- Selective combination of drive modules to control complex sequences of movements in injection moulds
- Wear-resistant plasticizing unit type
- Comprehensive list of options
- EC 200 machine control unit

ENGEL victory **combi** // Two or more injection units – for multicolour parts and combinations of materials.

- Clamping unit with extended platens and extended mounting height.
- Hydraulic system with variable displacement pumps for parallel movements
- Additional compact hydraulic injection unit
- L, V, W position (see also ENGEL combimelt brochure)
- Rotary modules with optimised diameter thanks to fully usable platen surface (the benefit of the tie bar-less machine!)
- Wear-resistant plasticizing unit type
- CC 200 Machine controller incl. comprehensive software package

Variant ENGEL victory ... / ...	focus	tech	power	combi
Clamping unit				
A platen (standard)	std	n.a.	n.a.	n.a.
B platen (vertically extended)	Option	std	std	std
C platen (vertically+horizontally ext.)	n.a.	Option	Option	Option
Frame extension (mould height adjustment)	n.a.	Option	Option	std
Injection unit				
Plasticizing barrel M1 with standard screw S1	std	std	n.a.	n.a.
Wear-resistant barrel M3 with tempered screw S8	Option	Option	std	std
Ceramic heating elements	std	std	std	std
Temperature controlled supply zone	std	std	std	std
Swivelling injection unit (up to unit 2550) * depending on layout of units	std	std	std	std*
Hydraulic system				
HV 0 (with variable displacement pump – for sequential sequence)	Std up to VC 500/120	n.a.	n.a.	n.a.
HV 1 (with variable delivery pump closed-loop pressure and speed control for sequential movements)	Std up to VC 650/120	std	n.a.	n.a.
HV 2 (with 2 variable delivery pumps – closed-loop pressure and speed control – for parallel movements)	n.a.	Option	std	std
HV 3, HV 4, HV 5, HV 6	n.a.	Option	Option	Option (up to HV4)
Machine control, electrics				
EC 200	std	std	std	n.a.
CC 200	Option	Option	Option	std
VirtMold (offline machine programming and simulation via PC)	Option	std	std	std
Socket 2-pin 230 V	std	std	std	std
Media				
Cooling water lines for mould cooling **Number depending on machine size	Std**	Std**	Std**	Std**
switching on/off of water manifold	Option	Option	std	std
General				
Machine mounts	std	std	std	std
Other order-specific custom options	n.a.	Option	Option	Option
Scope of equipment unlimited	No	Yes	Yes	Yes

Std: standard
n.a: not available

The System – the Technology Modules

The basic machines in the ENGEL victory series can be combined with process technology function modules. **Making custom machines from standard machines!**



ENGEL victory **rubber**

Reciprocating screw type injection unit with process technology geared for rubber processing – for low shot weights – can be utilized as an alternative to ENGEL elast series custom machines.

ENGEL victory **LIM**

With the equipment package for liquid silicone processing; reciprocating screw or plunger unit depending on application.

ENGEL victory **HTV**

Plasticizing unit and process software for solid silicone handling. Stuffing unit available as an option.

ENGEL victory **HARD-PVC**

Equipment package and plasticizing assemblies for processing hard PVC.

ENGEL victory **duroplast**

Special plasticizing assembly, processing software and hardware for mould heating for producing Duroplast moulded parts.

ENGEL victory **MuCell®**

Equipment package for manufacturing technical moulded parts with microfoam structure.

ENGEL victory **clean room**

Various equipment package stages to adapt the tie bar-less machine for production under clean room conditions.

The universal **small to mid-range machine** with the advantage of being tie bar-less

Injection unit	Available screw diameters [mm] per injection unit		
80 / ...	18	22	25
200 / ...	25	30	35
330 / ...	30	35	40
500 / ...	35	40	45
650 / ...	40	45	50
750 / ...	45	50	55
1050 / ...	50	55	60
1350 / ...	55	60	70
1800 / ...	60	70	80
2050 / ...	60	70	80
2550 / ...	70	80	85
3550 / ...	70	80	90
4550 / ...	80	90	105
5550 / ...	80	90	105
7050 / ...	90	105	120

* International dimensions, calculated as:
max. stroke volume [cm³] x max. injection pressure [bar] / 1000

Injection units*	80 / ...	200 / ...	330 / ...	500 / ...	650 / ...	750 / ...	1050 / ...	1350 / ...	1800 / ...	2050 / ...	2550 / ...	3550 / ...	4550 / ...	5550 / ...	7050 / ...
Clamping units															
victory ... / 28															
victory ... / 40															
victory ... / 50															
victory ... / 60															
victory ... / 70															
victory ... / 80															
victory ... / 90															
victory ... / 110															
victory ... / 120															
victory ... / 130															
victory ... / 150															
victory ... / 180															
victory ... / 220															
victory ... / 260															
victory ... / 300															
victory ... / 350															
victory ... / 400															
victory ... / 500															
victory ... / 600															

ENGEL Tie bar-less Small Scale Machines

ENGEL victory 80 / 40 focus



ENGEL Tie bar-less Mid-Range Machines

ENGEL victory 1800 / 400 power



The tie bar-less machine system – optimized ergonomics, robust, modular, expandable

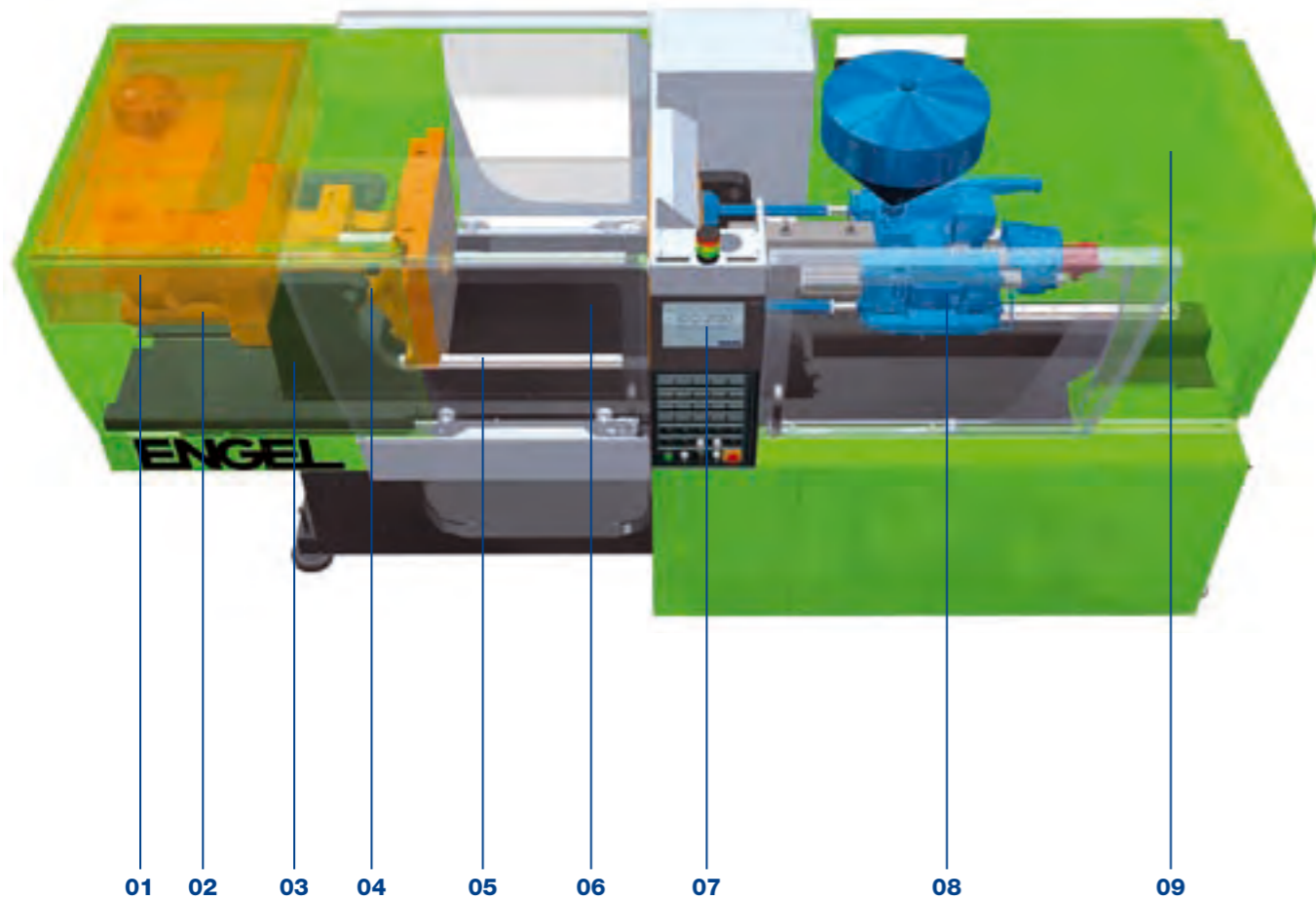

- | | |
|---|---|
| 01 Clamping cylinder | 06 Freely accessible mounting surface for injection moulds |
| 02 Hydraulic cylinder for movements | 07 Operating panel on EC 200 machine control unit with touch screen as man / machine interface |
| 03 C frame absorbs clamping force | 08 Compact hydraulic injection unit |
| 04 Flex-Link, the flexible interface between the clamping force cylinder and the moving platen | 09 Ergonomically optimized safety guard CE-compliant type |
| 05 Precision linear bearings for guiding and supporting the platen | |

Excellent Scope of Standard Features

The standard features of the fourth generation ENGEL tie bar-less machine system integrate user experience and feedback from 40,000 machines delivered to customers. The specific requirements of the machine users are the basis for ongoing enhancement of technical standards and detailed features.



Best conditions for any mould

The tie bar-less clamping unit is the specific characteristic of the ENGEL victory series. Barrier-free access to the mould mounting surface improves production efficiency. This gives customers the ability to mount bulky moulds, in a minimum amount of time, without having to remove machine components. Additionally, the tie bar-less clamping unit gives customers the best possible conditions for automating with any kind of part manipulation technology.



Swivelling injection unit (standard)

All ENGEL victory machines are fitted with a space-saving compact injection unit of suitable size and power. Injection occurs by means of two hydraulic barrels arranged in parallel. All hydraulic connections are implemented by means of drill holes in the cast frame. This makes the injection unit maintenance free for the most part. The injection unit can be swivelled (standard). This improves accessibility for maintenance of the plasticizing unit. A high speed mounting system for the barrel is standard. Depending on the machine size, the injection unit may be integrated in the machine's safety guard (open construction type).



Modular, hydraulic drive system

The design of the hydraulic drive system is modular: seven power levels are available (HV 0 to HV 6). This gives customers an option in any performance class, from simple standard applications to multiple component injection moulding with short cycle times. The service-friendly safety guards, with large access doors help to reduce service times.

Tie bar-less clamping unit: plenty of space for the injection mould and automation components

The ENGEL victory clamping unit:
The modern way of building injection moulding machines.

01 C frame

Instead of tie-bars, the tie bar-less C frame machines have two C-shaped frame elements to transmit force. The cross-section of the frame elements is about ten times larger than the tie-bar cross-section on comparable tie-bar machines. The result is the rigid system with minimal elastic deflection during the injection process.

02 Stationary platen

The stationary platen is supported by the large surface on the C frame. This means a greatly extended supporting surface in comparison to the 4-point support with tie bar machines. The benefits are far less bending of the platens, and thus improved support for the injection mould.

03 Moving platen

The moving platen is connected to the hydraulic pressure pad unit via Flex-Link, and supported and guided by precision linear bearings. The special Flex-Link construction ensures uniform force distribution and solid support for the injection mould.

04 Linear bearings for moving platen

Due to its design principle the solid C frame elements serve as the ideal mounting for the precision linear bearings. These linear bearings not only guide and support the platens but also bear the full weight of the mould. Oversized and overhanging moulds can be supported separately on the same guide to support the platen. Low friction precision bearings are an important requirement for the sensitivity of the mould protection system.

05 Flex-Link

Flex-Link is a maintenance free, flexible connection between the ram of the hydraulic clamping unit and the moving platen. It compensates for typical distortion and ensures optimum platen parallelism. Acquired parallelism values are 30% below the maximum levels recommended by EUROMAP. Frame bending curves and Flex-Link are harmonised. Flex-Link is pre-stressed, which guarantees platen parallelism over a wide range of different mould weights and sizes. Flex-Link is designed so that the ejector system is freely accessible.

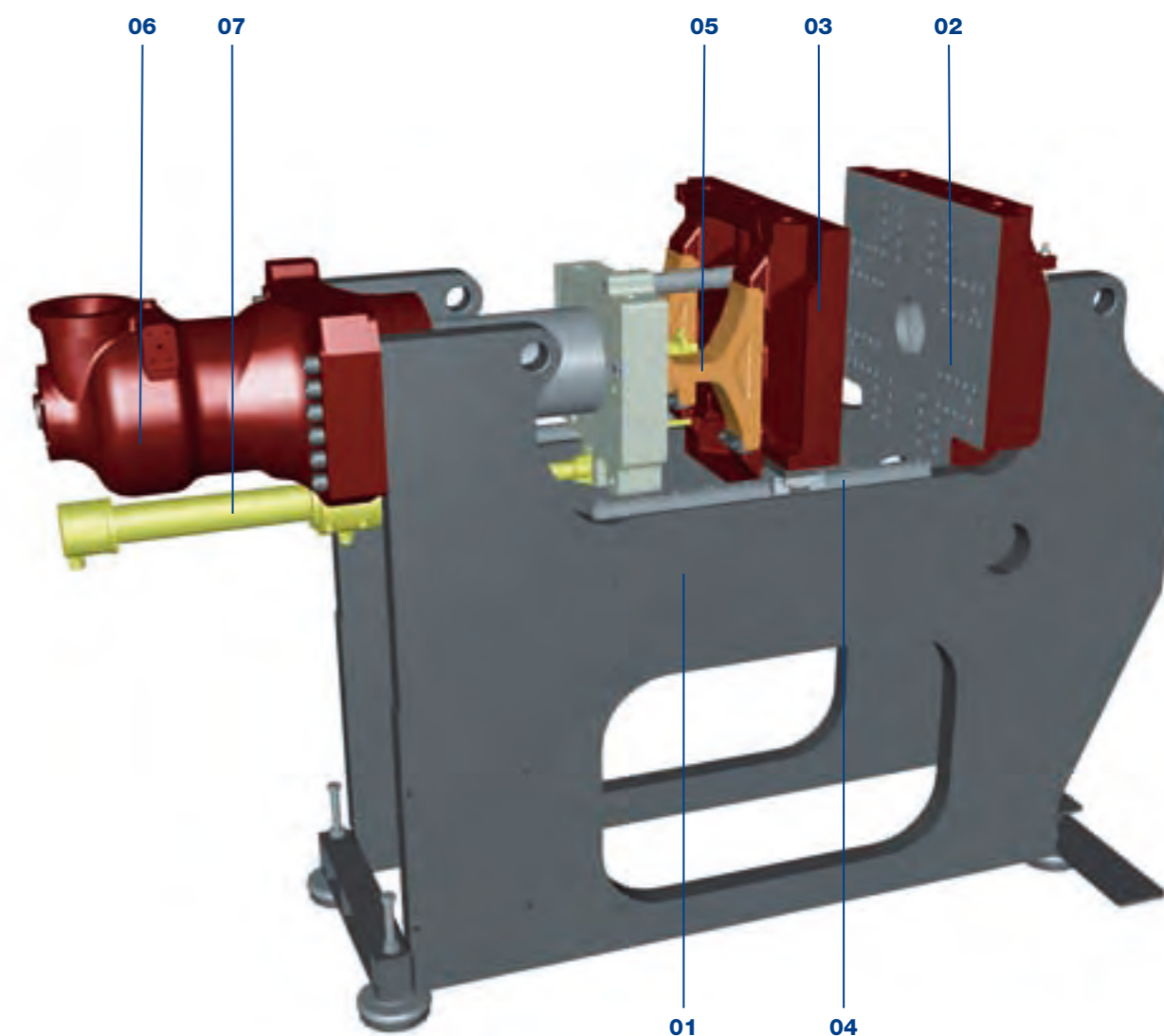

06 Pressure cylinder for clamping force build-up

07 Actuating cylinder with low volume of oil for fast opening and closing movements

Flexibility due to 3 platen sizes

Three platen sizes are available for optimum use of the mould mounting surface. Instead of standard mould mounting platens, vertically extended platens are optionally available, as are vertically and horizontally extended platens.

- A platen (standard)
- B platen vertically extended
- C platen, vertically and horizontally extended (thanks to frame extension / discharge chute)

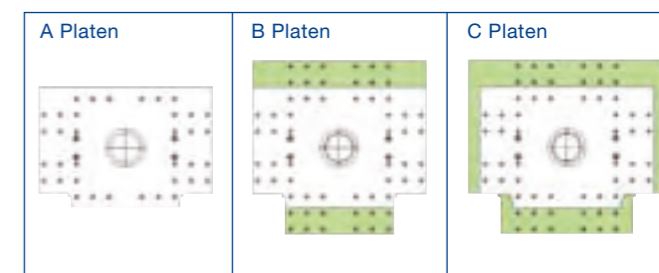



More than 360 equipment packages for molding flexibility

Power and media supplies to match requirements

ENGEL injection moulding machines can be diversified by adding options to create integrated production cells. The options for mould heating and media supply to the injection mould (closed circuit control systems for hot runner systems, hydraulics for core pulls, cooling water systems, compressed air connections) include media supply and distribution lines up to the connections on the plant floor. Media supplies can optionally be controlled via the machine controller or via an external control unit.

01

Mould mounting and changing made easy

Mould change made easy: ENGEL offers a hydraulically operated wedge clamping system, integrated in the platens, for injection moulds. In combination with a roller track system for lateral mould insertion into the clamping unit, automatic media couplings, and automatic ejector coupling, the high speed mounting system can be expanded in a modular manner to create a fully-automated system. The tie bar-less clamping unit with its generous space provides optimum conditions for this.

02

Waterflow control manifold

Waterflow control manifolds are ergonomically integrated into the safety guards: numbers and dimensions can be customized to reflect requirements – also as a retrofitting option. Optional types with or without electronic closed loop control of flow volume are available.

03

Extended safeguarding of mould space

Extended safety guards are required for operations with “bulky” moulds, such as moulds with protruding barrels (fitting moulds), or in cases where you need to integrate the pick & place robot directly with the clamping unit. A modular size range is available.

04

Cleanroom machines

Standard type ENGEL victory injection moulding machines provide an excellent platform for use in cleanroom production. The main reasons being the minimal number of moving parts and the excellent accessibility for periodic cleaning of the tie bar-less clamping unit. Matching equipment modules, developed to comply with c’GMP conditions help ENGEL to achieve maximum quality for cleanroom applications.





New design with optimised user ergonomics



Basic functions

- Switch on,
- User identification,
- USB interface

Settings: Clear-cut control logic

The control logic for the machine and robot support simple programming of an individual cycle sequence without special programming skills. The cycle sequence for the injection moulding process is subdivided into separate basic sequences. These basic sequences – closing, injection and opening – along with the additional subsequences are mapped to characteristic function icons.

“Function library“ for easier programming

Programming modules can be compiled from a comprehensive “function library“. Sequences are compiled in the Sequence Editor by inserting or removing functions. “Drag and Drop“ gives users the ability to select functions from a menu and integrate them with the sequence for serial and parallel execution.

Dialog-based customization supported

To change a parameter, users simply press the corresponding dialog box on the touchscreen and change the setting (e.g. for clamping force, closing or opening speed etc.). A plausibility check occurs after saving the modified data set to prevent incorrect settings.

Controls

Flexibly configurable keys for individual machine functions

Standard functions controlled through fixed pushbuttons

ENGEL EC 200 / CC 200

Tried and trusted machine controls geared to handle new demands

New operating convenience

- > Standardized – intuitively logical – user controls for the machine and robot
- > Continues the traditional ENGEL control logic, however, adapted to the world of Windows.
- > Uses a touch screen for input. Input can be entered via functional graphs or keyboard pop ups
- > Free programming of cycle sequence via graphical icons
- > Large selection of interfaces to industry standard peripheral units from the PC world

Depending on the complexity of your injection moulding project, and the resulting feature set, machines can optionally be equipped with the EC or CC 200 control unit variants. The range of additional options defines the difference. The EC 200 has a limited scope of available options and program packages, whereas the CC 200 has enhanced processor performance and a full range of options and custom programs. The basic functionality of the control units, and the control logic of the two variants, are identical.

For details of hardware and systems, please refer to the special brochure ENGEL control (EC 200 / CC 200)

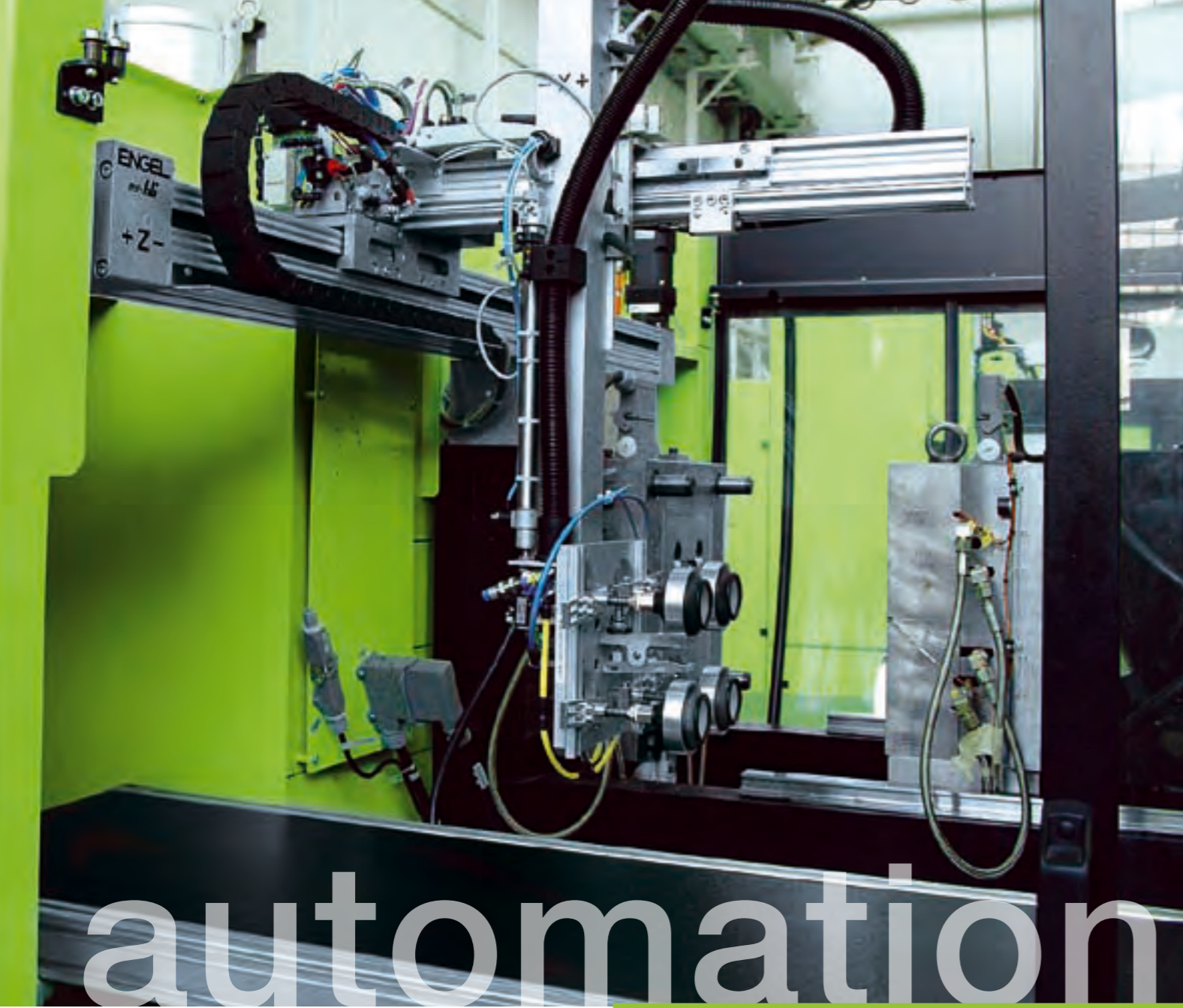

Tie bar-less system – the best foundation for automation

01 Complex production cells: ENGEL ERC linear robots

Combining the ENGEL ERC linear robot with the tie bar-less clamping unit facilitates the design of complex production cells. As there is no need to work around a top tie-bar, the machine height can be kept to a minimum – a big advantage in production shops with low ceiling height. In this case a combination with safeguarded automated peripheral units allow owners to operate the machine with open safety gates. An advantage that only ENGEL can offer.



02 Integrated automation: ENGEL ERC or ER HLI linear robot

A combination of the tie bar-less clamping unit and the automation module (ENGEL robot for tie bar-less machines) and an integrated conveyor-belt gives customers the ability to order a factory built production cell – including CE conformity ex works; various modular sizes are available. The low space requirement is an additional benefit of excellent system integration. (see also the figure on page 20)



03 Sprue removal: ENGEL ER USP Picker

Sprue removal and cutting are basic elements of automated injection moulding. For injection moulding machines with between 250 and 2.200 kN clamping force, Engel offers a fast universal device known as the USP (Universal Speed Picker), which is available in two sizes (500 and 700 mm Y stroke).



04 Automated NOK and start-up part separation

ENGEL has developed an innovative automation module for the machine's discharge chute to enable automatic separation of NOK parts or start-up parts. Flaps that are automatically actuated by the machine's quality management software separate the moulded parts discharged by the machine into OK, NOK, or quality control parts.



One major advantage of the tie bar-less clamping unit is unrestricted lateral access to the injection mould via a robot axis. There is no need to work around a tie-bar in contrast to legacy machines. This helps to save machine height on-site. This is a big advantage with low ceiling height machine shops. The shortest possible lateral take-off from the clamping unit reduces handling time to a minimum, making this approach ideal for production with short cycle times.

Centralized development – Production on three continents

victory



Production plant of uni-chains A/S-Vejle / Denmark

ENGEL Universal machines in global production operations

ENGEL has been building injection moulding machines for more than 50 years. Many years of experience, and talking to our customers, are some of the major factors that led to the development of injection moulding machines with tie bar-less clamping units.

40,000 units of this machine range for the production of small to medium-sized synthetic parts, which was first introduced in 1989, have been built and supplied to customers. The reference list sounds like a “Who is Who” of the industry. But machines have not only proved their value in large-scale facilities owned by global players, but also with start-ups, and small to mid-sized enterprises.



Partial view of a production plant with 64 ENGEL victory 330 / 75 type units for small precision parts

ENGEL builds victory machines at its own production facilities in Europe (Schwertberg / Austria), Asia (Pyungtaek / Korea) and America (Gueph / Canada). ENGEL has a network of subsidiaries and representatives in some 90 countries. This concept has helped the ENGEL victory to become a genuine „world machine“.

The application is not restricted to a specific branch. Precision and versatility are appreciated equally in automotive part production, medical technology, teletronics or technical injection moulding. This makes the ENGEL victory a genuinely universal machine for successful injection moulding that makes economic sense.